



USB/NDI/IP PTZ Camera 30x Zoom, PoE

User Manual

500790-V2



Table of Contents

1. Safety Precautions.....	3
2. Introduction.....	4
3. Features.....	4
4. Package Contents.....	4
5. Specifications.....	5
6. Operation Controls and Functions.....	7
6.1. Rear Panel.....	7
7. Dimension.....	8
8. Installation.....	9
8.1. Wall-Mount.....	9
9. Remote Control.....	10
10. OSD (On Screen Display) GUI Interface.....	11
10.1. Exposure.....	11
10.2. Color.....	12
10.3. Image.....	13
10.4. Display.....	13
10.5. P/T/Z Settings.....	14
10.6. Setting.....	15
10.7. Version.....	15
10.8. Default.....	16
11. Web Settings.....	16
11.1. Control Camera.....	16
11.2. Video Settings.....	18
11.3. Image Settings.....	19
11.4. Audio Settings.....	20
11.5. System Settings.....	20
11.6. Network Settings.....	21
11.7. NDI Settings (Optional).....	22
11.8. Device Information.....	23
11.9. Download Upgrade Program.....	23
12. Troubleshooting.....	23

1. Safety Precautions

To ensure the best performance from the product, please read all instructions carefully before using the device. Save this manual for future reference.

- Follow basic safety precautions to reduce the risk of fire, electrical shock, and injury.
- Do not dismantle the housing or modify the module. It may result in electrical shock or burns.
- Do not open or remove the housing of the device as you may be exposed to dangerous voltage or other hazards.
- To prevent fire or shock hazard, do not expose the unit to rain, moisture and do not install this product near water. Keep the product away from liquids.
- Spillage into the housing may result in fire, electrical shock, or equipment damage. If an object or liquid falls or spills on the housing, unplug the module immediately.
- Do not use liquid or aerosol cleaners to clean this unit. Always unplug the power to the device before cleaning.
- Using supplies or parts not meeting the product specifications may cause damage, deterioration or malfunction.
- Refer all servicing to qualified service personnel.
- Install the device in a place with adequate ventilation to avoid damage caused by overheat.
- Unplug the power when left unused for a long period of time.
- Information on disposal of devices: do not burn or mix with general household waste, please treat them as normal electrical waste.

Copyright Notice

All contents in this manual are copyrighted, and cannot be cloned, copied, or translated without the express permission of MuxLab Inc. Product specifications and information in this document are for reference only, and the content may be updated from time to time without prior notice.

2. Introduction

The MuxLab USB/NDI/IP PTZ Camera 30X Zoom, PoE (model: 500790-V2) is a full HD 1080p HDMI, USB and IP streaming camera with Pan, Tilt, and Zoom capability for extreme flexibility and reach. The camera supports uncompressed video via an HDMI or USB output for local connectivity, and H.264/H.265 compressed video for streaming over the Internet, while supporting a 30X optical zoom.

The USB/NDI/IP PTZ Camera 30X Zoom, PoE features an advanced AI algorithm that allows it to provide precise body tracking, supports PoE for convenience when powering the device, and a 1/2.7", 2.07 million effective pixels high-quality CMOS sensor to capture video. The camera supports a focal length of f4.42mm to 132.6mm, an aperture of F1.8 to 2.8, a shutter speed of 1/30s to 1/10000s, and a minimum illumination of 0.05 Lux for low-light conditions.

The USB/NDI/IP PTZ Camera 30X Zoom, PoE may be remotely managed via IP and RS232 for added convenience.

3. Features

- Maximum resolution of 1920 x 1080 (Full HD) at 60Hz
- Supports SDI, HDMI, USB 3.0 and network audio-visual output
- Built-in advanced AI algorithm that enables precise body tracking
- Supports Full NDI protocol
- Supports 30x optical zoom and 60.7° horizontal field of view
- Advanced Auto-focusing Technology
- Built-in dual microphone to capture sound
- Provides an economical solution for live streaming, conferencing and education.

4. Package Contents

- One (1) USB/NDI/IP PTZ Camera 30x Zoom.
- One (1) 100~240V AC 50/60Hz 24V-6.5A Power adapter
- One (1) RS232 Cable
- One (1) Remote Control
- One (1) Wall mount Bracket
- One (1) Ceiling mount Bracket
- User Manual can be downloaded from MuxLab website.

Notes: Confirm that the product and accessories are all included. If not, please contact the supplier from which you purchased the unit.

5. Specifications

Camera	
Video System	1080P60, 1080P59.94, 1080P50, 1080I60, 1080I59.94, 1080I50, 1080P30, 1080P29.97, 1080P25, 720P60, 720P59.94, 720P50
Sensor	1/2.8-inch high-quality UHD CMOS sensor with a maximum of 2.07 million pixels
Scanning Mode	Progressive scanning
Lens	30x, f4.42mm ~132.6mm, F1.8 ~ F2.8
Minimal Illumination	0.5Lux @ (F1.8, AGC ON)
Electronic Shutter	1/30s ~ 1/10000s
White Balance	automatic, manual, one touch, Specifying color temperature, indoor, outdoor
Digital Noise Reduction	2D, 3D digital noise reduction
Backlight Compensation	Supported
Video S/N	≥55dB
Horizontal Angle of View	60.7° ~ 2.28°
Vertical Angle of View	34.1° ~ 1.28°
Horizontal Rotation Range	±170°
Vertical Rotation Range	-30° ~ +90°
Pan Speed Range	1.7° ~ 100°/s
Tilt Speed Range	1.7° ~ 69.9°/s
H & V Flip	Supported
Image Freeze	Supported
Number of Presets	255
Preset Accuracy	0.1°
Audio	
Digital audio pickup	Built-in microphone array, 100Hz to 16KHz frequency response
Analog audio input	Supported 3.5mm Line-In
Digital audio output	Supported HDMI, USB, LAN, SDI audio output
Analog audio output	Supported 3.5mm Line-Out
USB Feature	
Operating System	Windows® 7, Windows 8.1, Windows 10 and up macOS™ 10.10 and up Google™ Chromebook™ Version 29.0.1547.70 and up Linux (only for UVC)
Hardware Requirement	2.4 GHz Intel® Core 2 Duo processor and up 2 GB internal storage and up USB 2.0 interface
Color System / Compression	YUY2/MJPEG/H.264
Video Format	video format of multi frame rate and resolution ratio, up to 1080P60 YUY2.
USB Video Communication Protocol	UVC 1.1 or UV C1.5
Audio on USB	32K sampling frequency, supported UAC2.0
UVC PTZ	Supported

IP Camera	
Video Compression	H.264
Video Stream	First and second streaming
Main Stream Resolution	1920x1080, 1280x720, 1024x576, 960x540, 640x480, 640x360
Sub Stream Resolution	1280x720, 1024x576, 720x576, 720x480, 720x408, 640x360, 480x270, 320x240, 320x180
Video Bit Rate	32Kbps ~ 102400Kbps
Bit Rate Type	Variable bit rate, Fixed bit rate
frame rate	1fps ~ 60fps
Audio Compression	AAC
Audio Bit Rate	96Kbps, 128Kbps, 256Kbps
Supported protocols	FULL NDI, NDI HX, TCP/IP, HTTP, RTSP, RTMP, Onvif, DHCP, Multicast, SRT, GB/T28281
Input/Output Interface	
USB	1-ch, USB 3.0: Type-A
HD Output	1 x HDMI: V1.3
Network Interface	1 x 3G-SDI: BNC type, 800mVp-p, 75Ω, Comply with SMPTE 424M standard 1 x RJ45:10M/100M/1000M Adaptive Ethernet, supported PoE
Audio interface	1 x Line In, 3.5mm Audio Interface 1 x Line Out, 3.5mm Audio Interface
Communication Interface	1 x RS232 In: 8pin Min DIN, Max Distance: 30m, VISCA/Pelco-D/Pelco-P 1 x RS232 Out: 8pin Min DIN, Max Distance: 30m, VISCA network use only 1 x RS485: 2-POS Terminal Block, Max Distance: 1200m, VISCA/Pelco-D/Pelco-P
Power Jack	JEITA Type (Input 12VDC)
Generic Specification	
Input Voltage	12VDC, PoE (802.3af)
Input Current	1000mA
Operating Temperature	0°C ~ 40°C
Storage Temperature	-10°C ~ 50°C
Power Consumption	12W
Size	146mm x 169mm x 168mm
Net Weight	1.5Kg
Warranty	2 years
Order Information	500790-V2 USB/NDI/IP PTZ Camera 30x Zoom, PoE (UPC: 627699017906)

6. Operation Controls and Functions

6.1 Rear Panel

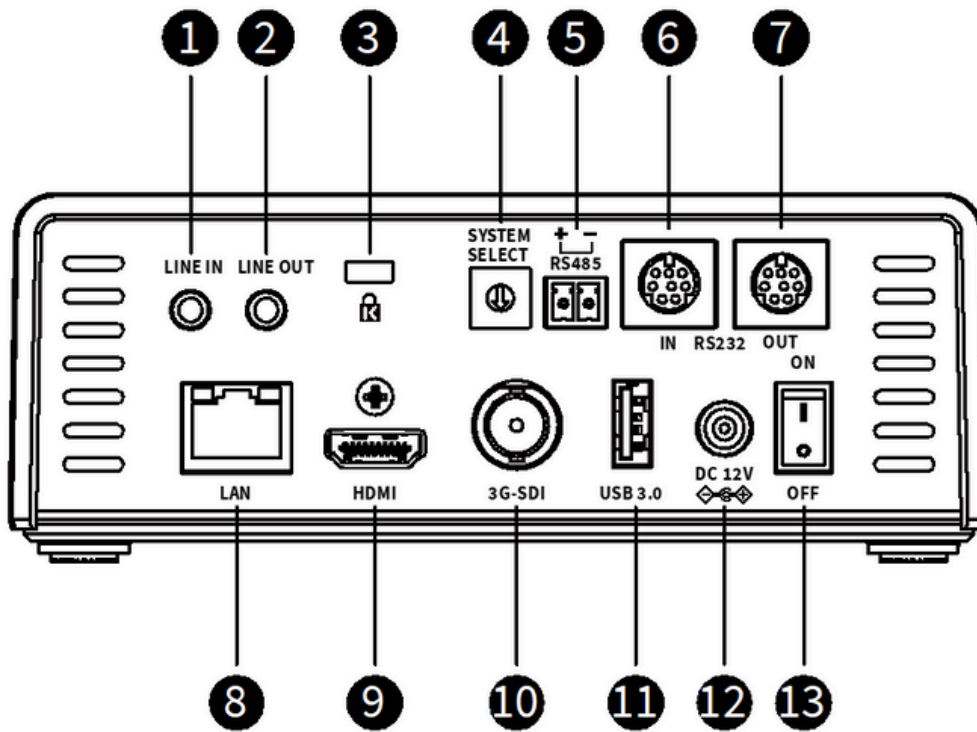

No	Name	Function Description
1	LINE IN	LINE IN Interface
2	LINE OUT	LINE OUT Interface
3		Security Slot
4	System Select	System Select Switch
5	RS485	RS485 Interface
6	RS232 IN	RS232 IN Interface
7	RS232 OUT	RS232 OUT Interface
8	LAN	LAN Interface
9	HDMI	HDMI Interface
10	3G-SDI	3G-SDI Interface
11	USB 3.0	USB 3.0 Interface
12	DC 12V	DC 12V Interface
13	ON / OFF	Power Switch

7. Dimension

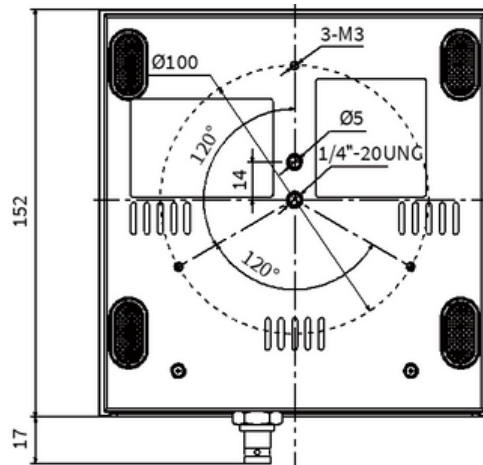
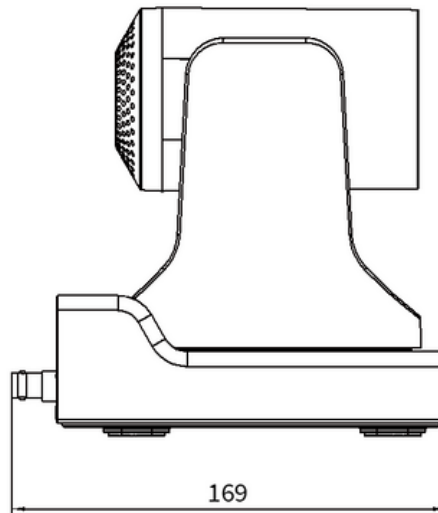
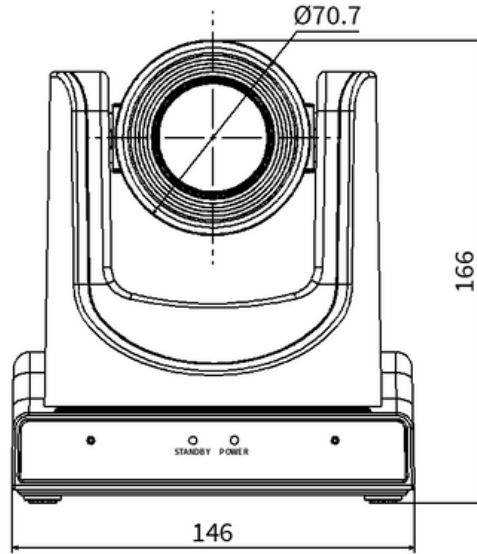

8. Installation

8.1 Wall-Mount

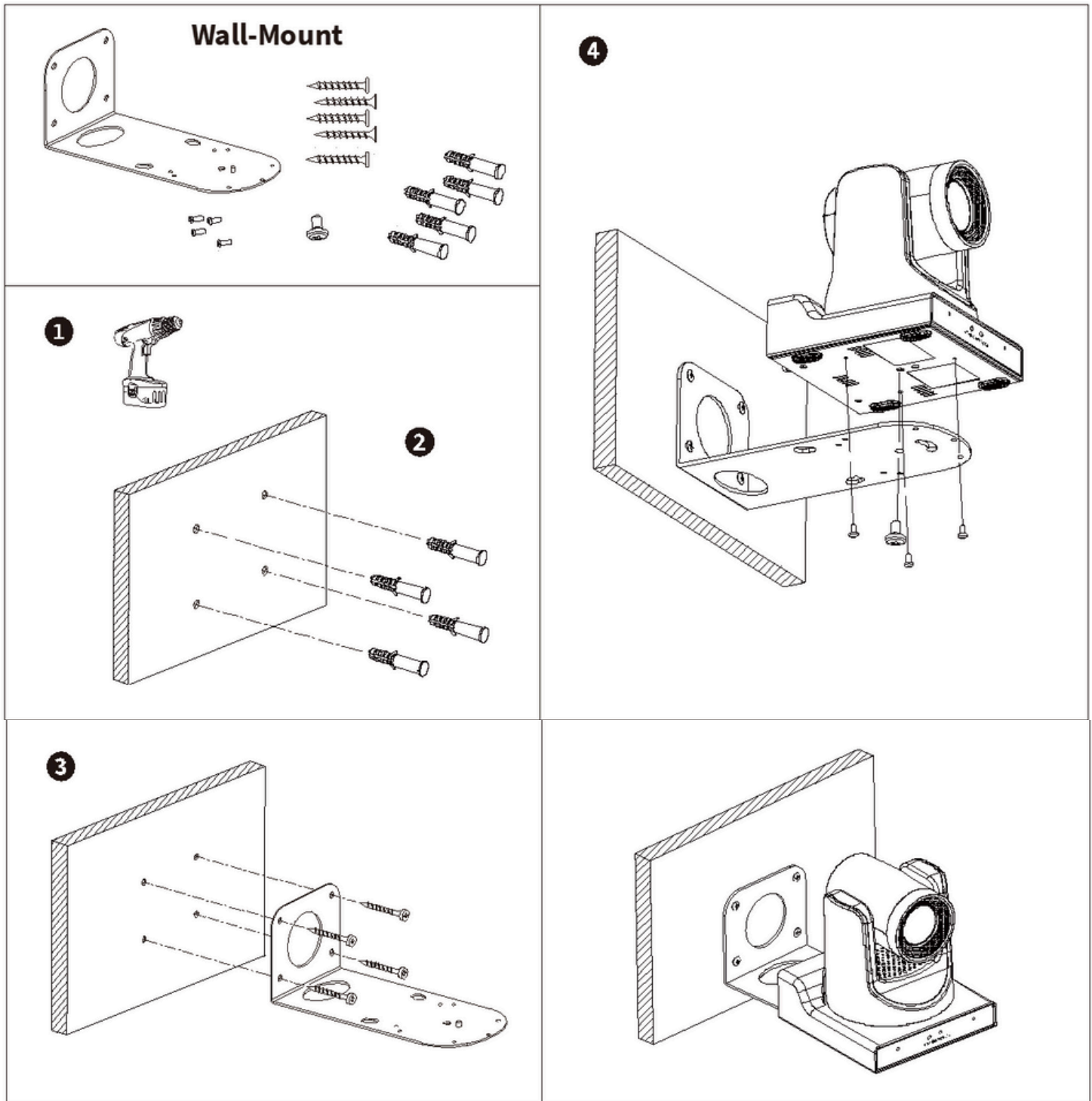

9. Remote Control

Key Description

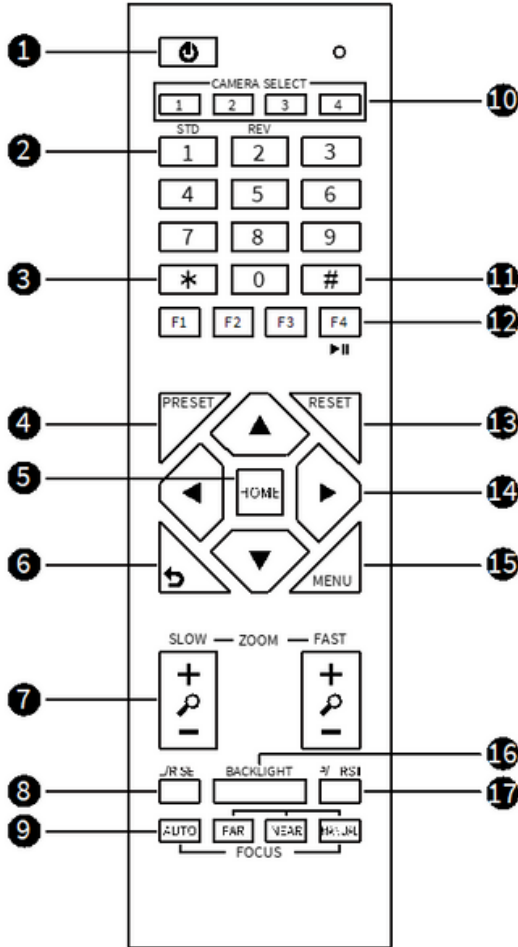

1. **Standby Key:** Press to enter standby mode
2. **Number Key:** Press to set preset or call preset
3. *** Key:** Use with other keys
4. **PRESET Key:** Set preset: [PRESET] + Number key (0-9)
5. **HOME Key:** Confirm selection or press to turn PTZ back to the middle position.
6. **Return Key:** Press to return to the previous menu
7. **ZOOM Key:** SLOW: Zoom In [+] or Zoom Out [-] slowly
FAST: Zoom In [+] or Zoom Out [-] fast
8. **L/R SET Key:** Standard: Simultaneously press L/R SET + 1
Reverse: Simultaneously press L/R SET + 2
9. **FOCUS Key:** Auto/Manual/Far/Near focus
10. **Camera Select Key:** Press to select and control the camera
11. **# Key:** Use with other keys
12. **IR Remote Control Key:** [*]+[#]+[F1]: Address 1
[*]+[#]+[F2]: Address 2
[*]+[#]+[F3]: Address 3
[*]+[#]+[F4]: Address 4
13. **RESET Key:** Clear preset position: [RESET] + Number key (0-9)
14. **PTZ Control Key:** PTZ moved according to the arrow indicates

15. **MENU Key:** Press to enter or exit OSD (On Screen Display) Menu

16. **BACKLIGHT Key:** Backlight ON/OFF: Press repeatedly to enable or disable the backlight compensation.

NOTE: Effective only in auto exposure mode; If there is a light behind the subject, the subject will become dark, press the backlight key to enable the backlight compensation. Press again to disable this function.

17. **P/T RST (PTZ Reset) Key:** PTZ starts to self-test after pressing it.

Shortcut Set

- [*]+[#]+[1]: OSD menu default English
- [*]+[#]+[3]: OSD menu default Chinese
- [*]+[#]+[4]: Display current IP address
- [*]+[#]+[6]: Quickly recover the default
- [*]+[#]+[8]: View the camera version
- [*]+[#]+[9]: Quickly set up inversion
- [*]+[#]+[MANUAL]: Restore default IP address.

10. OSD (On Screen Display) GUI Interface

Press [MENU] key to display the main menu on the normal screen, using arrow key to move the cursor to the item to be set. Press the [HOME] key to enter the corresponding sub-menu.

Menu	
ENG/中文	ENG
AI MODE	Off
Video Format	1080P60
Style	Default
Exposure	->
Color	->
Image	->
Display	->
PTZ Setting	->
Setting	->
Version	->
Default	->

[MENU] Return / [HOME] Enter

- **ENG/中文:** ENG, 中文.
- **AI MODE:** Off, Single Track, Frame Track, Demo Mode.
- **Video Format:** 1080P60, 1080P50, 1080I60, 1080I50, 1080P30, 1080P25, 720P60, 720P50
- **Style:** Default, Cold, Warm, Clear, Soft, User1, User2, User3.

10.1 Exposure

Move the main menu cursor to [Exposure], and press [HOME] key enter the exposure page, as shown in the following figure.

Exposure	
>	AE Auto
	Flicker 50Hz
	Expcomp Mode On
	Expmode 2
	Backlight Off
	Gain Limit 15
	DRC Mode Off

[MENU] Return / [HOME] Enter

- **AE:** Auto, Manual, Iris Priority, Shutter Priority, Bright Priority.
- **Flicker:** Off, 50Hz, 60Hz (Effective only in Auto, Iris Priority, Bright Priority mode).
- **Expcomp Mode:** On, Off (Effective only in Auto, Iris Priority mode).
- **Expmode:** -7~7 (Effective only in Expcomp Mode to On).
- **Backlight:** On, Off (Effective only in Auto, Iris Priority mode).
- **Bright:** 0~99 (Effective only in Bright Priority mode).
- **Gain Limit:** 0~32 (Effective only in Auto, Iris Priority, Bright Priority mode).
- **ris:** F1.8, F2.0, F2.4, F2.8, F3.4, F4.0, F4.8, F5.6, F6.8, F8.0, F9.6, F11, Off (Effective only in Manual, Iris Priority mode).
- **Shutter:** 1/30, 1/50, 1/60, 1/90, 1/100, 1/125, 1/180, 1/250, 1/350, 1/500, 1/725, 1/1000, 1/1500, 1/2000, 1/3000, 1/4000, 1/6000, 1/10000 (Effective only in Manual, Shutter Priority mode).
- **Gain:** 0~31 (Effective only in Manual, Shutter Priority mode).
- **DRC Mode:** Manual, Auto, Off.
- **DRC:** 0~14 (Effective only in DRC Mode to Manual).

10.2 Color

Move the main menu cursor to [Color], and press [HOME] key enter the color page, as shown in the following figure.

Color	
>	AWB Auto
	Sens Low
	R-Tuning 0
	B-Tuning 0
	Hue 50
	Saturation 100
[MENU] Return / [HOME] Enter	

- **AWB:** Auto, VAR, Manual, One Push, Indoor, Outdoor.
- **Sens:** Low, Middle, High.
- **R-Gain:** 0~1023 (Effective only in Manual, One Push mode).
- **B-Gain:** 0~1023 (Effective only in Manual, One Push mode).
- **R-Tuning:** -128~128 (Effective only in Auto, Temp, One Push mode).
- **B-Tuning:** -128~128 (Effective only in Auto, Temp, One Push mode).
- **Hue:** 0~99.
- **Saturation:** 0~200.
- **Temp:** 2000 ~ 8500 (Effective only in Temp mode).

10.3 Image

Move the main menu cursor to [Image], and press [HOME] key enter the image page, as shown in the following figure.

Image		
>	Brightness	50
	Contrast	50
	Sharpness Mode	Auto
	Gamma Mode	Manual
	Gamma	Ext
	NR-2D Mode	Auto
	NR-3D Mode	Auto
[MENU] Return / [HOME] Enter		

- **Brightness:** 0~99.
- **Contrast:** 0~99.
- **Sharpness Mode:** Manual, Auto.
- **Sharpness:** 0~25 (Effective only in Sharpness Mode to Manual).
- **Gamma Mode:** Manual, Auto.
- **Gamma:** Ext, 0.45, 0.5, 0.54, 0.56, 0.63 (Effective only in Gamma Mode to Manual).
- **NR-2D Mode:** Manual, Auto.
- **NR-2D:** 0~99 (Effective only in NR-2D Mode to Manual).
- **NR-3D Mode:** Manual, Auto.
- **NR-3D:** 0~15 (Effective only in NR-3D Mode to Manual).

10.4 Display

Move the main menu cursor to [Display], and press [HOME] key enter the display page, as shown in the following figure.

Display		
>	OSD-Dir	0
	Frac Rate	Off
	HDMI Mode	HDMI
	SDI Mode	Level A
	Flip-H	Off
	Flip-V	Off
	Freeze	Off
[MENU] Return / [HOME] Enter		

- **OSD-Dir:** 0, 90, 180, 270.
- **Frac Rate:** On, Off.
- **HDMI Mode:** HDMI, DVI.
- **SDI Mode:** Level A, Level B.
- **Flip-H:** On, Off.
- **Flip-V:** On, Off.
- **Freeze:** On, Off.

10.5 P/T/Z Settings

Move the main menu cursor to [P/T/Z Setting], and press [HOME] key enter the P/T/Z setting page, as shown in the following figure.

P/T/Z Setting	
>	AF-Sense High
	AF-Zone Front
	Focus Limit Off
	LR Mode STD
	Motion Sync Off
	Horizontal Speed 23
	Vertical Speed 19
	Zoom Speed 7
	PTbyZoom On
[MENU] Return / [HOME] Enter	

- **AF-Sense:** High, Normal, Low.
- **AF-Zone:** Front, Top, Center, Bottom.
- **Focus Limit:** On, Off.
- **Near Focus Limit:** 1M, 1.5M, 2M, 3M, 4M, 5M, 6M, 8M, 10M, 15M, 20M (Effective only in Focus Limit to On).
- **Far Focus Limit:** 15M, 20M, Infinity (Effective only in Focus Limit to On).
- **LR Mode:** STD, REV.
- **Motion Sync:** On, Off.
- **Horizontal Speed:** 0~23.
- **Vertical Speed:** 0~19.
- **Zoom Speed:** 0~7.
- **PTbyZoom:** On, Off.

10.6 Setting

Move the main menu cursor to [Setting], and press [HOME] key enter the setting page, as shown in the following figure.

Setting	
>	Visca Addr 1
	Visca Mode Series
	Baud Rate 9600
	DHCP Off
	IP Addr 192.168.100.88
	MAC d4e08e548d13
[MENU] Return / [HOME] Enter	

- **Visca Addr:** 1~7 (Effective only in VISCA protocol).
- **Visca Mode:** Serial, Paral.
- **Baud Rate:** 2400, 4800, 9600, 19200, 38400, 57600, 115200.
- **DHCP:** On, Off.
- **IP Addr:** 192.168.100.88.
- **MAC:** d4e08e548d13.

10.7 Version

Move the main menu cursor to [Version], and press [HOME] key enter the version page, as shown in the following figure.

Version	
Main	X8.02.15
AF	14.04.04
Date	2022-08-18
Code	VF1
NDI License	Okay
[MENU] Return / [HOME] Enter	

- **Main:** Display the version number of the main program of the camera.
- **AF:** Display the camera autofocus version number.
- **Date:** Display the burning date of the main program version of the camera.
- **Code:** Display the camera code.
- **NDI License:** Display NDI license verification results.

10.8 Default

Move the main menu cursor to [Default], press [HOME] key enter default page, as shown in the following figure.

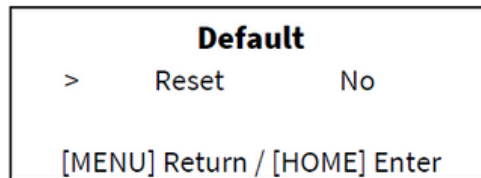

- **Reset:** Yes, No.

11. Web Settings

Access <http://192.168.100.88> to pop up the login window, then input username (default: admin) and password (default: admin). After login, it will show as below:



11.1 Control Camera

All pages include two menu bars:

Real time monitoring: displaying video image
Parameter setup: with function buttons.

A. Video Viewing Window

Video viewing window must be same as video resolution, the bigger the resolution is, the bigger the playing area is. Double click viewing window, will show full-screen, double click again, will return to initialized size.

Status bar in viewing window shown as below:

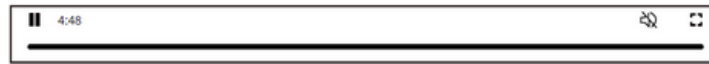

- 1) **Video playback pause button:** control real-time video pause, stop the last picture, click recoverable video again.
- 2) **Audio control buttons:** can adjust the volume or set silent mode.
- 3) **Full screen switch button.**

B. PTZ Setup

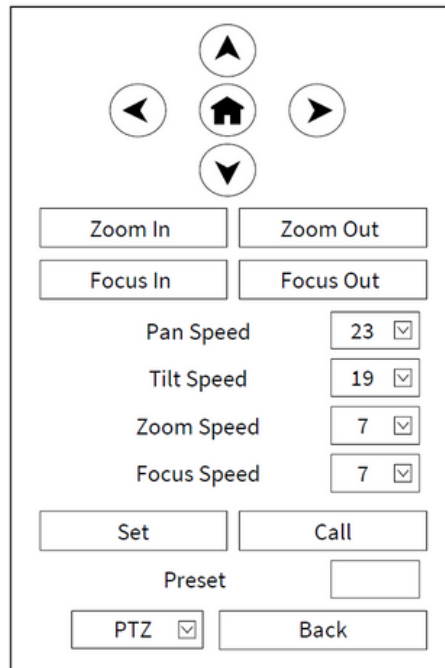

- 1) **Pan and Tilt Control:** Up, Down, Left and Right arrows and the home button allow you to manually drive the camera to the desired position.
- 2) **Zoom:** Zoom In and Zoom Out buttons allow for wide or narrow view of the space.
- 3) **Focus:** Focus In and Focus Out buttons allow for fine manual focus adjustment if the camera has any problems auto focusing on the difficult object.
- 4) **PTZ Speeds:** Pan speed can be set at any rate between 1 ~ 24, Tilt speed can be set at any rate between 1 ~ 20. Zoom and Focus speeds can be set at any rate between 1 ~ 7.

5) **PTZ Presets:** After manually setting up a shot that you would like to return to later, you can save presets for quick recall of these positions. Type a number between 0 and 254 into the Preset box. Click the "Set" button to save the current location with that preset number. Click the "Call" button to cause the camera to return to that position. This enables smooth, quick and convenient control without the need to manually drive the camera. You can set up preset that user want as below.

Method: Type preset number into the Preset box.



Preset: Optional items: 0 ~ 254.

6) **PTZ/OSD Dropdown:** From the dropdown menu, clicking the OSD option will open the on-screen display menu of the camera giving you control from within the IP interface.

C. Language Selection

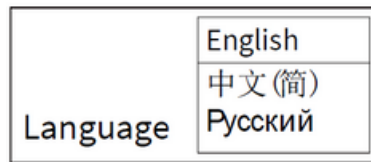

Click either "Chinese", "English" or "Russian" to change the language of the webpage.

11.2 Video Settings

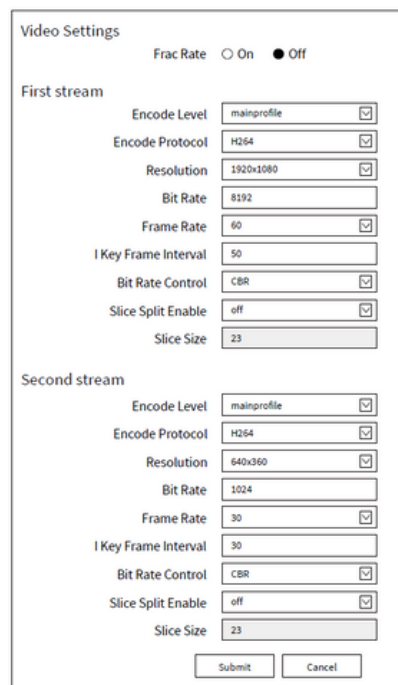

- 1) **Frac Rate:** Turn On/Off Frac Rate.
- 2) **Encode Level:** Support baseline, main profile, high profile and svc-t four levels.
- 3) **Encode Protocol:** Support H.264 and H.265 protocols.
- 4) **Resolution:** First stream support 1920x1080, 1280x720, 1024x576, 960x540, 640x480, 640x360. Second stream support 1280x720, 1024x576, 720x480, 640x360, 480x272, 320x240, 320x180; The bigger resolution is, the clearer the image will be, more network bandwidth will be taken.
- 5) **Bit Rate:** The user can specify the bit rate. Generally speaking, the larger of the bit rate, the clearer of the image. However, the configuration of the bit rate needs to be combined with the network bandwidth. When the network bandwidth is narrow and the bit rate is configured larger, the video stream cannot be transmitted normally, and the visual effect is worse.
- 6) **Frame Rate:** User can specify the size of the frame rate, generally, the frame rate greater, the image more smooth; Frame rate is smaller, the more sense of beating.
- 7) **I Key Frame Interval:** Set interval between 2 I frame, the bigger interval is the response will be lower from viewing window.
- 8) **Bit Rate Control:**
Code stream control way:
CBR (Constant Bit Rate): Video coder will be coding according to preset speed.
VBR (Variable Bit Rate): Video coder will adjust the speed based on preset speed to gain the best image quality.
- 9) **Slice Split Enable:** Enable or disable slice split function.
- 10) **Slice Size:** Set the size of slice.

11.3 Image Settings

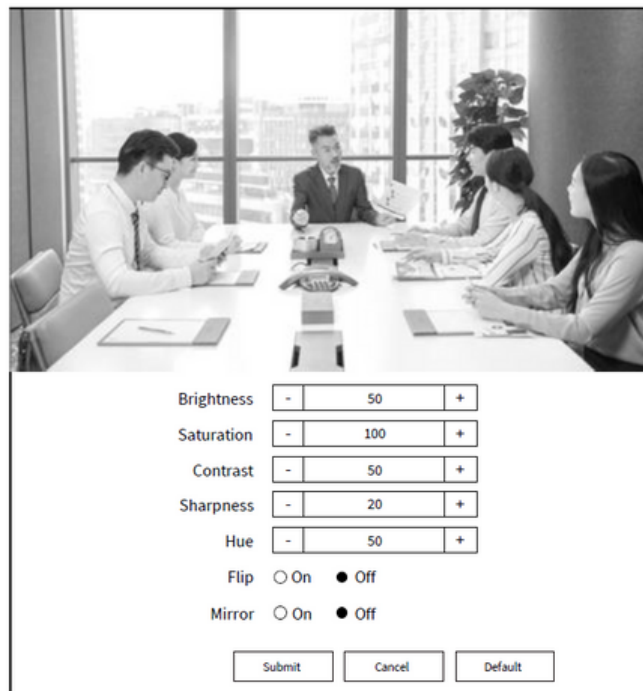

- 1) **Brightness:** Brightness of image: 0~99 (Default value is 50).
- 2) **Saturation:** Saturation of image: 0~200 (Default value is 100).
- 3) **Contrast:** Contrast of image: 0~99 (Default value is 50).
- 4) **Sharpness:** Sharpness of image: 0~99 (Default value is 20).
- 5) **Hue:** Hue of image: 0~99 (Default value is 50).
- 6) **Flip:** Turn On/Off the Flip function.
- 7) **Mirror:** Turn On/Off the Mirror function.

11.4 Audio Settings

- 1) **Audio Switch:** Turn On/Off audio switch.
- 2) **Audio Type:** Optional items: AAC.
- 3) **Sample Rate:** Optional items: 32K, 48K.
- 4) **Bit Rate:** Optional items: 96K, 128K, 256K.
- 5) **Input Type:** Optional items: LINE IN, MIC.
- 6) **Input Vol L:** The volume of the left channel.
- 7) **Input Vol R:** The volume of the right channel.

11.5 System Settings

- 1) **Reboot:** Click the "Reboot" button, system restart.
- 2) **Username and Password:** The user can modify the password (letters and Numbers only).

11.6 Network Settings

Lan Settings

IP Configuration Type:

IP Address:

Subnet Mask:

Gateway:

DNS Address:

MAC Address:

NTP Settings

Time Zone:

Server Address:

Time Show: On Off

Position: X Y

Subtitle Display: On Off

Subtitle Content:

Port Settings

HTTP Port:

RTSP Port:

TCP Port:

UDP Port:

Sony Visca:

RTMP(S) Settings

First Stream: On Off

MRL:

Second Stream: On Off

MRL:

SRT Settings

SRT: On Off

SRT Port:

SRT Encryption:

SRT Password:

RTSP Settings

RTSP Auth: On Off

ONVIF Settings

ONVIF: On Off

ONVIF Auth: On Off

- 1) **Lan Settings:** Default the IP address is 192.168.100.88, the MAC address cannot be modified.
- 2) **NTP Settings:** Setting NTP Time Zone and Server Address. Turn On/Off Time Show, set the position of the Time Show. Turn On/Off Subtitle Display, set the Subtitle Content of the camera screen.
- 3) **Port Settings:**
 - HTTP Port: IP address identifies network device, the device can run multiple web applications, each network program using network port to transmit data, so data transmission to be carried out between the port and port. Port setting is to set up web server program using which port to transmit. When port mapping, need to be consistent with the port number (default port: 80).
 - RTSP Port: The camera support RTSP protocol, use the VLC tools broadcast, default port: 554.
 - TCP Port: Support TCP connection then control camera, default port: 5678.
 - UDP Port: Support UDP protocol, default port: 1259.
 - Sony Visca: Support Sony Visca, default value: 52381.
- 4) **RTMP(S) Settings:** Turn On/Off first stream or second stream, setting the MRL of RTMP.
- 5) **SRT Settings:** Turn On/Off SRT, Setting the SRT Port, SRT Encry and SRT Password.
- 6) **RTSP Settings:** Turn On/Off RTSP Auth.
- 7) **ONVIF Settings:** Turn On/Off ONVIF and ONVIF Auth.

11.7 NDI® Settings (Optional)

NDI® Settings

NDI®|HB On Off

NDI License

Server IP

Group Name

Key

NDI® Firmware Version

- 1) **NDI®|HB:** Turn On/Off NDI®|HB.
- 2) **NDI License:** Display NDI License verification results.
- 3) **Server IP:** Setting NDI® Server IP address.
- 4) **Group Name:** Setting NDI® Group Name.
- 5) **Key:** Setting NDI® Key.
- 6) **NDI® Firmware Version:** Display NDI® Firmware Version.

11.8 Device Information

Information

Device ID	<input type="text" value="HD Camera"/>
Device Type	<input type="text" value="V.F1"/>
Software Version	<input type="text" value="X8.02.15"/>
Webware Version	<input type="text" value="v1.5.5"/>
Device Serial Number	<input type="text" value="X6v19260f6c9"/>

11.9 Download Upgrade Program

Please check the MuxLab website for the current software version and if upgrade is required.

12. Troubleshooting

The monitor shows no image

- Check that the camera power supply is connected, the voltage is normal, and the power indicator light is always on.
- Turn off the power switch to check whether the camera is self-testing.
- Check the cable of video platform and TV whether correct connection.

The video image displayed by the camera lens is jittery

- Check whether the camera installed position be stabled.
- Check whether have vibrating machinery or object near the camera.

There is no video image in Browser

IE browser does not support H5, you need to use VLC plug-in to view videos. Please access VLC website (<http://www.videolan.org/vlc>) download and install the 32-bit VLC media player, after it installed, access camera will have normal image display. Other mainstream browsers already support H5 and do not need to install the VLC plug-in.

Unable to access camera through Browser

- Using PC to access the network to test whether the network access can work properly, first of all, the network fault caused by the PC virus can be eliminated, until the PC and camera can communicate with each other Ping.
- Disconnect the network, connect camera and PC separately, and reset the IP address of PC.
- Check IP address, subnet mask, and gateway settings for camera.
- Check whether the MAC address is conflicts.
- Check whether the web port is modified. The default web port is 80.

Forget the IP address or login password

Please remember (The default IP address: 192.168.100.88; default user name: admin; default password: admin).

Remote control cannot control

- Check and replace the new battery for the remote controller.
- Check whether the camera working mode is correct.
- Check whether the address of remote control can match the camera.

Serial port cannot control

- Check whether the camera protocol, address and baud rate such is the same.
- Check whether the control line is connected well.