



USB/Wireless Speakerphone Kit

User Manual

500798



Table of Contents

1. Safety Precautions.....	3
2. Introduction.....	4
3. Features.....	4
4. Package Contents.....	4
5. Specifications.....	5
6. Operation Controls and Functions.....	5
6.1. Front and Side Panel.....	5
6.2 Rear Panel.....	5
6.3 Wireless Microphones.....	6
6.4 USB/Wireless Speakerphone Operation.....	6
6.5 Wireless Microphones Operation.....	8
7. Connection Diagram.....	9

1. Safety Precautions

To ensure the best performance from the product, please read all instructions carefully before using the device. Save this manual for future reference.

- Follow basic safety precautions to reduce the risk of fire, electrical shock, and injury.
- Do not dismantle the housing or modify the module. It may result in electrical shock or burns.
- Do not open or remove the housing of the device as you may be exposed to dangerous voltage or other hazards.
- To prevent fire or shock hazard, do not expose the unit to rain, moisture and do not install this product near water. Keep the product away from liquids.
- Spillage into the housing may result in fire, electrical shock, or equipment damage. If an object or liquid falls or spills on the housing, unplug the module immediately.
- Do not use liquid or aerosol cleaners to clean this unit. Always unplug the power to the device before cleaning.
- Using supplies or parts not meeting the product specifications may cause damage, deterioration or malfunction.
- Refer all servicing to qualified service personnel.
- Install the device in a place with adequate ventilation to avoid damage caused by overheat.
- Unplug the power when left unused for a long period of time.
- Information on disposal of devices: do not burn or mix with general household waste, please treat them as normal electrical waste.

Copyright Notice

All contents in this manual are copyrighted, and cannot be cloned, copied, or translated without the express permission of MuxLab Inc. Product specifications and information in this document are for reference only, and the content may be updated from time to time without prior notice.

2. Introduction

The USB/Wireless Speakerphone Kit (model: 500798) is meticulously crafted to cater to a spectrum of space sizes, ranging from intimate huddle spaces to expansive conference rooms. With a built-in 4-microphone array complemented by 2 extension microphones and a high-fidelity speaker, this kit stands out. Additionally, it provides the option to seamlessly connect with two wireless extension microphones, expanding its reach to capture voices from a distance. The hassle of wiring is eliminated, offering a convenient and swift setup.

This speakerphone kit incorporates an advanced 3A audio algorithm, ensuring top-notch performance in echo cancellation, noise suppression, and gain control. These features collectively guarantee crystal-clear voice transmission, enhancing communication quality during meetings. Moreover, the kit boasts versatility by being compatible with Android, Windows, and Mac operating systems. Connectivity is a breeze, supporting both wireless and USB cable connections, providing a flexible and user-friendly experience for diverse setups.

3. Features

- Adaptive Space Coverage
- Microphone Array
- Omnidirectional voice pickup
- Up to 10 hours battery operation
- Wireless Extension Microphones
- Dynamic background noise reduction
- Wireless connection

4. Package Contents

- One (1) USB/Wireless Speakerphone (Main)
- Two (2) Wireless microphones
- One (1) 1.5meters USB Type-C cable
- One (1) USB Wireless Receiver
- One (1) User manual (available via download)

Notes: Confirm that the product and accessories are all included. If not, please contact the supplier from which you purchased the unit.

5. Specifications

Specification	
Microphone Array	Built-in 6 Microphone Array, Voice Pickup Range Up to 10 meters
Speaker	Built-in Hi-Fi Speaker DSP Audio Acoustic echo cancellation and noise reduction Dynamic speech enhancement
Power Supply	5VDC
Battery (main unit)	Built-in 3000mAh battery
Battery (2x remote units)	Built-in 2000mAh battery
Warranty	2 years
Order Information	500798 USB/Wireless Speakerphone Kit (UPC: 627699007983)

6. Operation Controls and Functions

6.1 Front and Side Panel

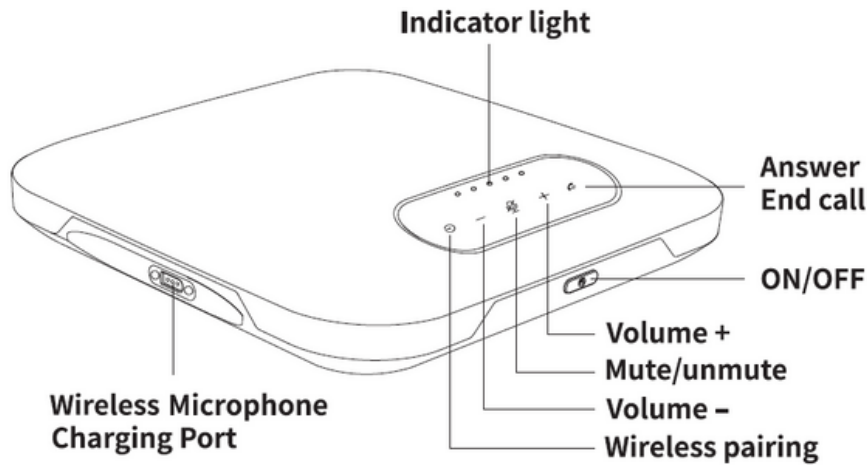

6.2 Rear Panel

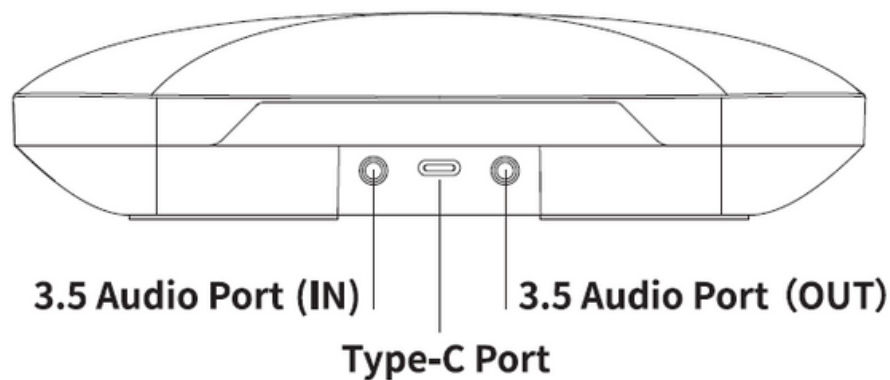

6.3 Wireless Microphones

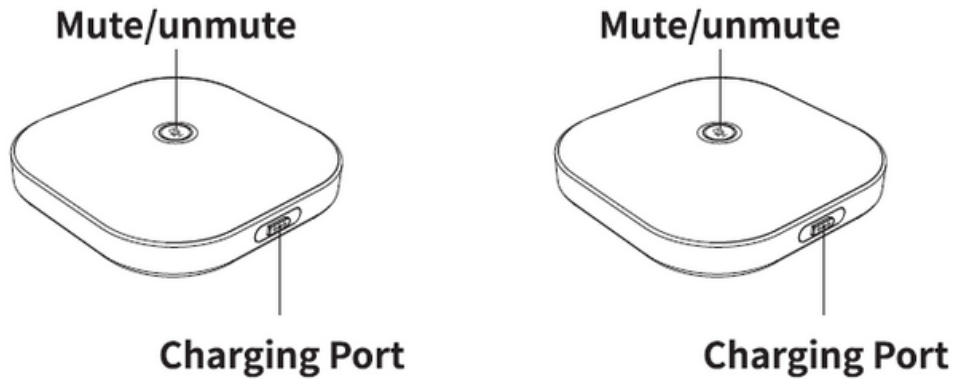

6.4 USB/Wireless Speakerphone Operation

1. Power On/Off: Press the ON/OFF button for 3 seconds, the USB/Speakerphone will turn on or off with a hint tone.

2. Bluetooth Connect and Disconnect:

- After power on, press the wireless pairing button for 2 seconds to start pairing mode. You will hear "Paring" with a white and blue flashing light.
- Turn on the Bluetooth on your device and chose to connect with the USB/Wireless Speakerphone.
- A short click on the Paring button will cancel the pairing with your device, this will turn the flashing light to turn white.
- To disconnect, press the Pairing button for 2 seconds. You will hear hint tone with the blue light turning white.

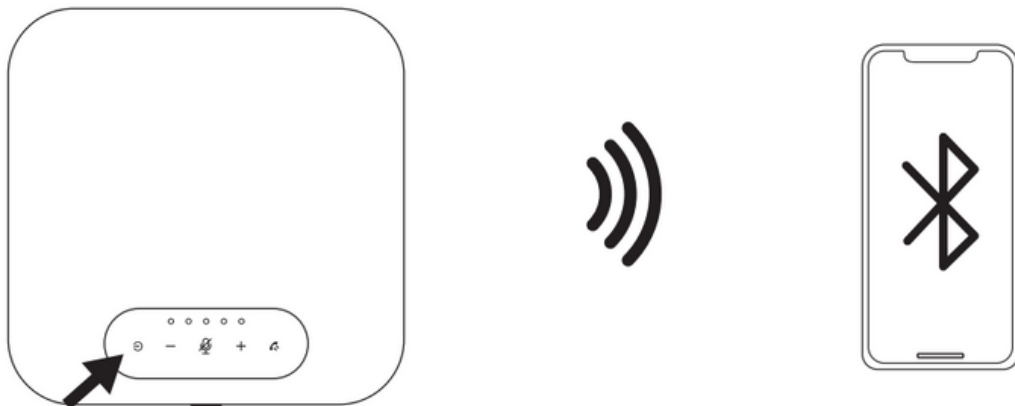

3. Connect using the USB cable: Simply connect the USB cable to a computer and start using the USB/Wireless Speakerphone.

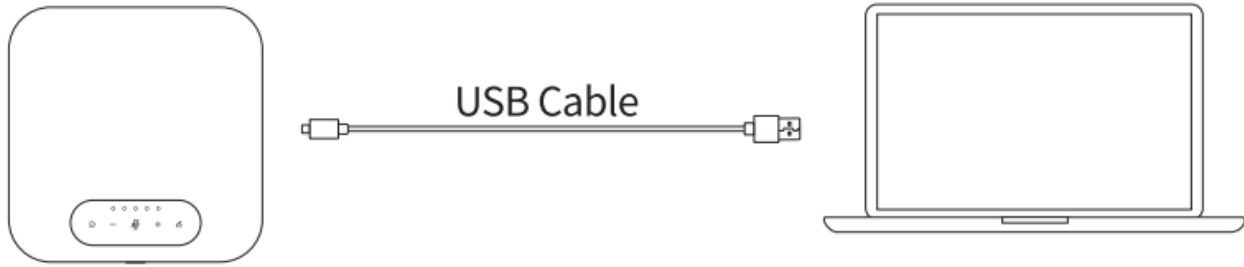





4. Connect using wireless receiver: Connect the USB wireless receiver to a computer and start pairing mode on speakerphone, wait for about 15 seconds until the pairing is completed then the speakerphone is connected and ready to go.

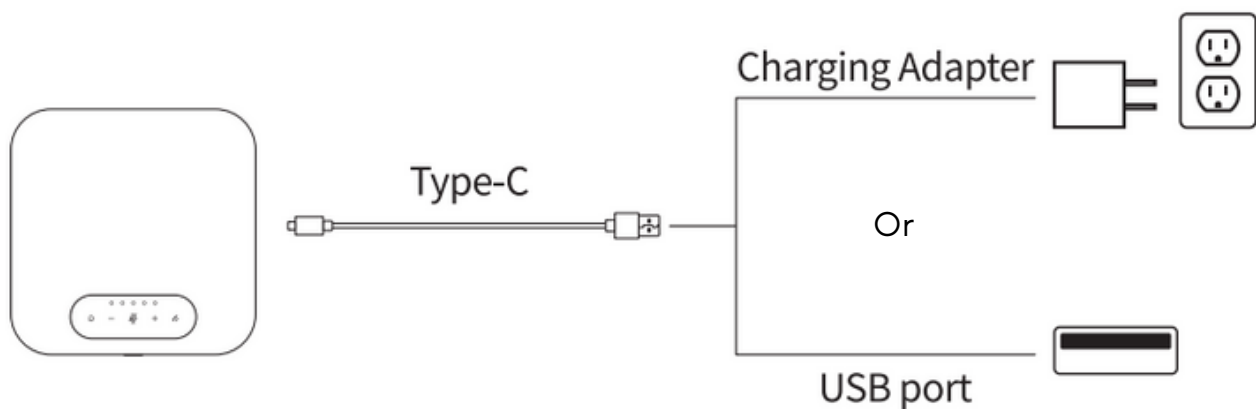

5. Charging the USB/Wireless Speakerphone (Main): Connect the USB cable to a charging adapter or to any USB charging port.



- 6. Answer/end calls:** Press  button to answer calls, press  button to end calls
- 7. Speaker volume up/down:** Press  button to increase the speaker volume, press  button to lower the speaker volume.
- 8. Mute:** To mute the microphones, press the mute button  on either the main Speakerphone or the wireless microphones.
- 9. Automatic turn off:** If the device is not connected for 15 minutes, it will turn off automatically.
- 10. Battery level:** When charging or short pressing the power key, the green light is the charging/power level indicator. During charging, there will be a flashing green light and a full green light when charging is completed.

6.5 Wireless Microphone Operation

- 1. Power On/Off:** Press the Mute button for 3 seconds, the Wireless microphone will turn on or off.
- 2. Connect and Disconnect:**
 - Long press mute button on the extension mics for about 6s, the white light will flash quickly to enter pairing mode, then long press on the call key and power key of main Speakerphone for about 6s to start pairing.
Note: Wireless microphones should have been paired with the main Speakerphone before delivery. In special cases, please refer to this method to pair them again if they were disconnected.
 - When the Wireless Microphone is disconnected with the main Speakerphone, the white light will be flashing, and the Wireless microphone will automatically shut down after 18 minutes.
 - When the main Speakerphone is shut down, the connected Wireless Microphones will shut down as well.
- 3. Charging the Wireless Microphones** is simply done by connecting the magnetic charging connector near the main Speakerphone charging ports.
Note: the light will turn red when battery is low, flashing green when charging and full green when charging is completed.

7. Connection Diagram

Connection via USB cable

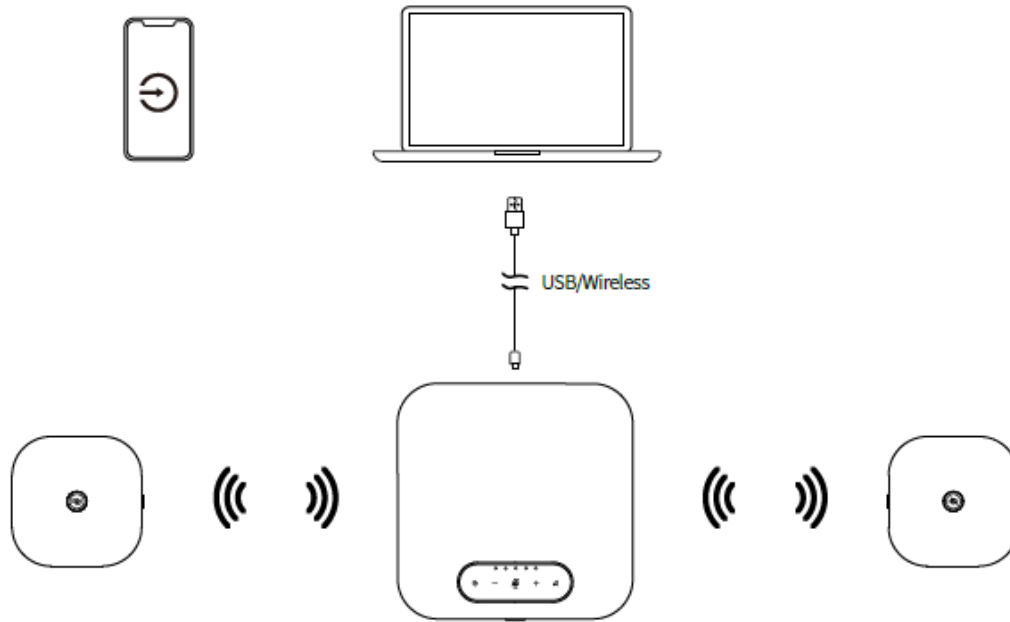

Connection via USB wireless receiver

