

### Overview

The Surface Mount Transceiver Plate (500916) allows most MuxLab desktop transmitters and receivers to be installed on a wall or furniture surface for a more permanent and secure installation.

Head-end AV equipment such as DVD players, video servers and sat boxes may be installed in a local wiring closet and connected to the Cat5e/6 structured cabling system via a wide array of MuxLab desktop transceiver solutions.

The 500916 fully covers the transceiver and allows the connectors to be accessed for ease of use. Mounting ears are positioned to allow multiple fixtures to be installed next to each other.

The 500916 comes with four (4) mounting screws and plastic anchors for drywall (gyproc) installation.



### Applications

- Custom AV installations
- Head-end audio-video systems
- Home AV systems
- Boardroom systems
- Digital signage systems

### Features & Benefits

- One-piece design
- Ease of install – no need to remove stand-offs
- Includes four (4) mounting screws and anchors
- Compatible with 500110, 500141, 500150, 500390, 500407, 500410, 500417, 500450, 500700. Transceivers sold separately

<b>Environment</b>	Custom audio-video systems in a structured cabling environment.
<b>Application</b>	Wall or furniture surface-mounting of MuxLab transceivers in head-end installations, audio-video rooms, telecom rooms, boardroom systems, classrooms, CCTV systems.
<b>Capacity</b>	One medium size MuxLab desktop transceiver
<b>Compatible transmitter and receivers</b>	MuxLab transmitters and receivers measuring: 4.50" x 3.00" x 1.25" (11.4 x 7.6 x 3.2 cm). i.e. 500110, 500141, 500150, 500390, 500407, 500410, 500417, 500450, 500700. *Rubber stand-offs must be applied to the base unit
<b>Orientation</b>	Transceivers may be installed front or rear facing.
<b>Enclosure</b>	Aluminum. Black painted
<b>Mounting holes</b>	Four (4) mounting holes and two (2) slotted holes
<b>Mounting hardware</b>	Four (4) mounting #6 screws and Four (4) anchors are included.
<b>Dimensions</b>	5.58" (W) x 3.12" (H) x 1.44" (D) (14.2 cm x 7.93 cm x 3.65 cm)
<b>Shipping Weight</b>	1.2 oz (34 gms)
<b>Warranty</b>	Lifetime
<b>Order Information</b>	500916 Surface Mount Transceiver Plate UPC: 627699009161

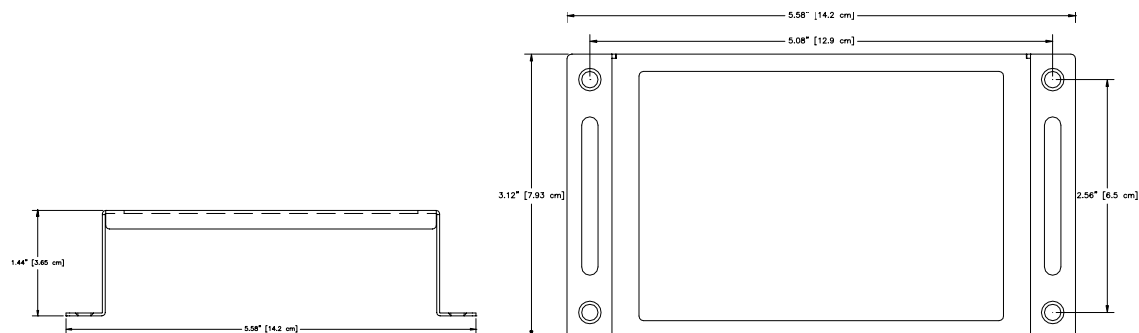

### MuxLab Inc.

8495 Dalton Road, Mount Royal, Quebec, Canada, H4T 1V5

Tel: (514) 905 0588 Fax: (514) 905 0589

Toll Free: 877 689-5228 (North America)

E-mail: [videoease@muxlab.com](mailto:videoease@muxlab.com)

URL: [www.muxlab.com](http://www.muxlab.com)

**Typical Application**

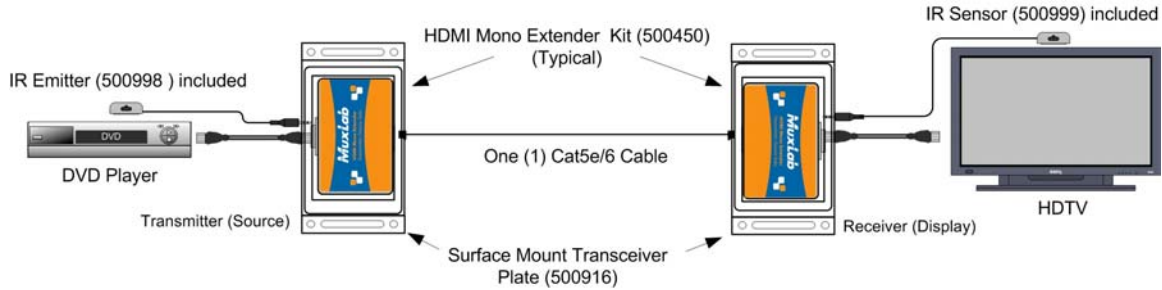

With transceiver installed

