

Specifications

Environment	Component Video (YPbPr), RGB Video (sync on green). 480i/p, 720p, 1080i/p. Line level analog audio.
Devices	DVD players, satellite receivers, plasma displays, projectors, monitors, up-converters, amplifiers, switchers, home theatre and other equipment supporting HDTV component video and/or analog audio.
Transmission	Transparent to the user
Bandwidth	Video: 60 MHz, 3 dB roll off Analog audio: 20 Hz to 20 kHz
Maximum Input	1.1 Vp-p
Insertion Loss per Pair (Video)	0.1 dB for 0.1 MHz Gradually increasing to 3.0 dB over the frequency range
Insertion Loss per Pair (Audio)	Less than 2 dB per pair over the frequency range
Return Loss (Video)	Greater than 15 dB over the frequency range
Common Mode Rejection Ratio (Video)	-55 dB max.
Common Mode Rejection Ratio (Audio)	Greater than 60 dB at 1 kHz Greater than 40 dB over the frequency and distance range
Max. Distance Color via Cat 5E/6 UTP/STP Cable	480i/p: 1,000 ft (305 m) 720p and 1080i: 500 ft (152 m) Analog Audio: 3,250 ft (990 m)
Cable: Cat 5E/6 UTP/STP	24 AWG or lower solid copper twisted pair wire Impedance: 100 ohms at 1 MHz Maximum capacitance: 20 pF/ft Attenuation: 6.6 dB/1,000 ft at 1 MHz
Cable: Coax	Impedance: 75 ohms at 1 MHz
Connectors	Three RCA-F connectors: Green (Y), Blue (Pb), Red (Pr) One (1) RCA-F connector for analog audio RJ45S for twisted pair
Pin Configuration Reverse polarity sensitive	Red (Pr): Pins 7(R) & 8(T) Green (Y): Pins 3(R) & 6(T) Blue (Pb): Pins 1(R) & 2(T) Analog Audio: Pins 4(R) & 5(T)
Temperature	Operating: 0° to 55°C Storage: -20° to 85°C Humidity: Up to 95% non-condensing
Enclosure	ABS fire retardant plastic, Color white, Finish glossy.
Dimensions	86 mm x 86 mm x 36 mm. Choose 40 mm deep back box to allow for Cat 5E/6 wiring connection.
Weight	4.1 oz (115 g)
Regulatory	FCC, CE, RoHS, European Standard for 86 mm faceplate
Warranty	Lifetime
Order Information	500053-WP-US Component Video / Analog Audio Wall Balun UPC: 6-27699-91053-5

MuxLab

8495 Dalton Road, Mount Royal, Quebec, Canada. H4T 1V5

Tel: (514) 905-0588 Fax: (514) 905-0589

Toll Free (North America): (877) 689-5228

E-mail: videoease@muxlab.com URL: www.muxlab.com



Component Video/Analog Audio Wall Balun 500053-WP-US Quick Installation Guide

Overview

The Component Video/Analog Audio Wall Balun (500053-WP-US) allows one component video (YPbPr or RGB) signal and one Analog Audio signal to be transmitted via a cost-effective unshielded twisted pair (UTP) cable. Used in pairs, or in conjunction with the 500048 or 500049, the Component Video/Analog Audio Wall Balun supports 480i/p, 720p and 1080i/p resolution for hi-definition (HDTV) video applications. The product allows four coaxial cables to be replaced by one Category 5E/6 twisted pair cable allowing standard structured cabling techniques to be used for more efficient cabling.

Installation

One (1) pair of baluns is needed to complete one component (YPbPr/RGB) connection via Cat 5E/6 twisted pair. To install the baluns, perform the following steps:

1. Identify the pin configuration of the baluns. Three (3) twisted pairs are required for video and one (1) twisted pair is required for optional analog audio. The pin configuration follows the EIA/TIA 568A/B standard. The Component Video/Analog Audio Balun is reverse polarity sensitive. Please ensure that wiring is straight-through (Ring to Ring, Tip to Tip).

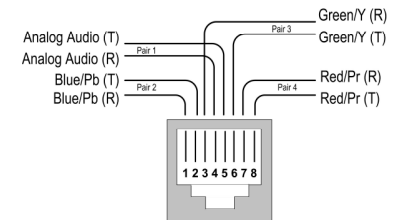

- To install the balun in a single back box, choose a back box with a depth of 40 mm or more. Connect the RJ45 plug into the rear of the balun. Secure the balun with the 2 front screws.
- Place a Decora® faceplate (not included) and secure with the 2 front screws.
- Plug one (1) balun into the component video coaxial cable output of the video source according to the color code of the RCA connectors.
- Plug the second balun into the component video coaxial cable input of the video screen or receiver at the remote end.
- Complete the connection between the two baluns, using standard Cat 5E/6 twisted pair cable and connecting hardware, terminated on RJ45 plugs at both ends. Ensure that there are no split pairs or taps.
- If analog audio is to be connected (optional), connect an RCA lead between the balun and the analog audio equipment at both ends.
- Power-on the component video equipment. Check the image quality and refer to the troubleshooting table below if the image quality is unsatisfactory. The following diagram shows a typical installation.

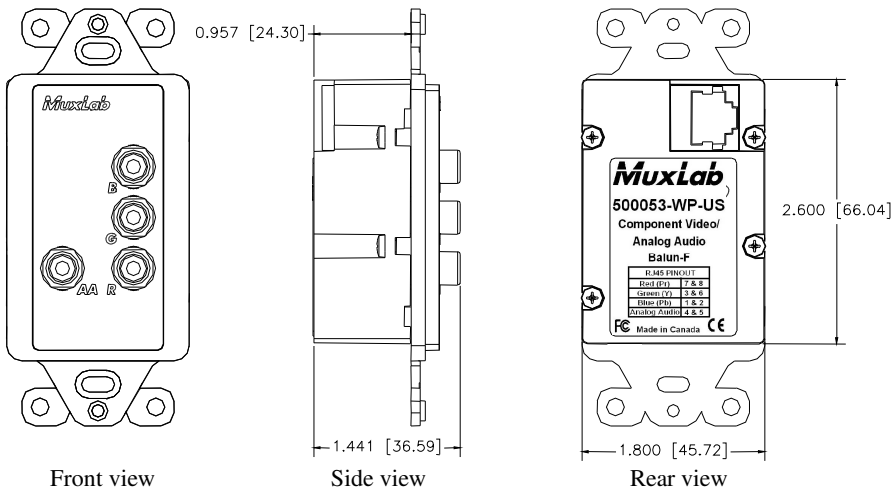
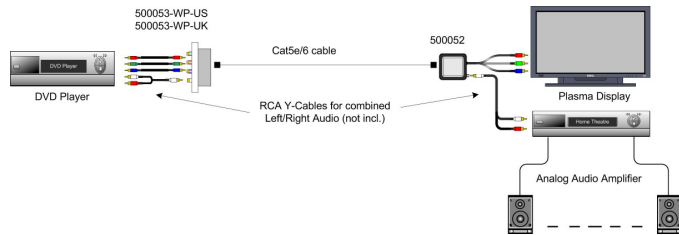
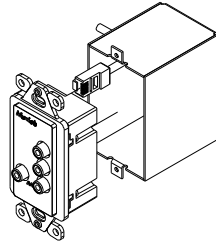

Troubleshooting

The following tables describe some of the symptoms, probable causes and possible solutions in respect to the installation of the Component Video/Analog Audio Balun:

Video Symptom	Probable Cause	Possible Solutions
No video	No continuity in video link	Verify cable continuity between pairs of baluns.
	Power off	Check power supplies of video equipment.
	Improper connection and/or swapped pairs	Check that baluns are connected to correct video inputs and outputs.
Unusual colors	Reversed polarity	Check wiring and ensure straight-through polarity.
Background pattern	EMI interference	Identify possible radiating frequency sources (<i>i.e.</i> , wireless LANs, switching power supplies). Try to isolate them from the video connection. Use shielded twisted pair grounded at both ends.
Smearing	Exceeded distance	Verify cable grade. Use higher grade cable if necessary.
Weak contrast	Exceeded distance	Verify cable grade. Use higher grade cable if necessary. Increase contrast on monitor.
	Unusual link attenuation	Verify cable distance using ohmmeter or cable tester.
Image not stable	Defective link or equipment	Verify video equipment interface integrity.
Horizontal bars moving slowly	Substantial crosstalk between multiple video sources	Consecutively turn off other video sources to determine which video source is the cause of interference.
Snowy picture	Distance is near limit	Verify cable grade. Use higher grade cable if necessary. Reduce color intensity at monitor.

Audio Symptom	Probable Cause	Possible Solutions
Poor audio quality	EMI interference	Check that wiring is not too close to transformers and ballasts.
	Split pair	Ensure that the UTP pairs are not split and that each pair of wires is twisted.
No audio	No power	Check your audio system for power.
	Open circuit	Check wiring to ensure continuity.
	Defective balun	Change baluns for another pair.
Audio phase cancellation	Reversed wires	Check for straight-through wiring.
Audio weak	Distance specifications exceeded	Check DC loop resistance and verify if distance spec is exceeded. Reduce cable length or eliminate high-loss components.

If you still cannot diagnose the problem, please call MuxLab Customer Technical Support at 877-689-5228 (toll-free in North America) or (+1) 514-905-0588 (International).